



MODEL EF651615
Lithium Thionyl Chloride
(Li-SOCl₂) Battery

(International size reference: LTC-3PN, EF651615)

ELECTRICAL CHARACTERISTICS

(typical values for cells stored for one year or less, at 25°C)

■ **Nominal capacity** **0.40Ah**
 (at 0.5 mA, +25°C, 2.0V cut off. The capacity restored by the cell varies according to current drain, temperature and cut off voltage.)

■ **Rated voltage** **3.6 V**

■ **Maximum recommended continuous current** **5 mA**
 (to get 50% of the nominal capacity at +25°C with 2.0V cut off. Higher currents possible.)

■ **Pulse capability:** varies according to pulse characteristics (frequency and duration), temperature, cell history (storage conditions prior to usage) and the application's acceptable minimum voltage.

■ **Maximum pulse current capability** **20 mA**
Rated 1 sec. pulse capability (to 3V) **10 mA**

■ **Storage** (recommended) **30°C max**
 (possible without leakage) **-55° / +120°C**

■ **Operating temperature range** **-55° / +85°C**
 (Operation at temperature different from ambient may lead to reduced capacity and lower voltage plateau readings.)

⚠ WARNING:

Fire, explosion and severe burn hazard. Do not recharge, crush, disassemble, heat above 212°F (100°C), incinerate, or expose contents to water.

KEY FEATURES

- ✓ High and stable operating voltage
- ✓ High minimum voltage during pulsing
- ✓ Low self discharge rate (less than 1% after 1 year of storage at +25°C)
- ✓ Stainless steel container
- ✓ Hermetic glass-to-metal sealing
- ✓ Non-flammable electrolyte
- ✓ Compliant with IEC 86-4 safety standard and EN 50020 intrinsic safety
- ✓ Non restricted for transport

⚠ Underwriters Laboratories (UL) Component Recognition (File Number MH 47566)

MAIN APPLICATIONS

- ✓ Utility metering
- ✓ Alarms and security devices
- ✓ Memory back-up
- ✓ Tracking systems
- ✓ Automotive electronics
- ✓ Professional electronics ... etc.

DISCHARGE CHARACTERISTICS @ +25°C

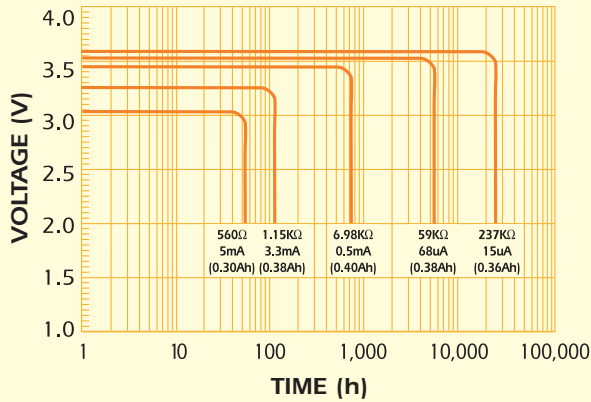

EF651615

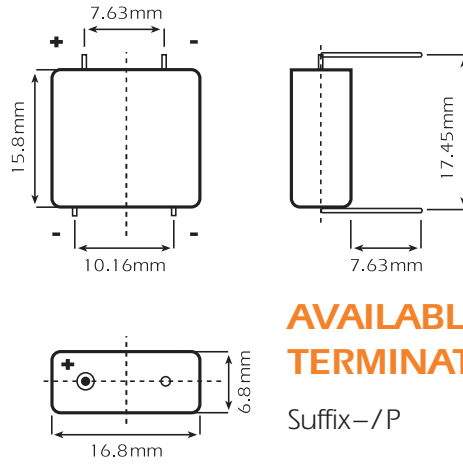

AVAILABLE TERMINATIONS

Suffix -/P Tinned Nickel Pins

VOLTAGE VS. TEMPERATURE

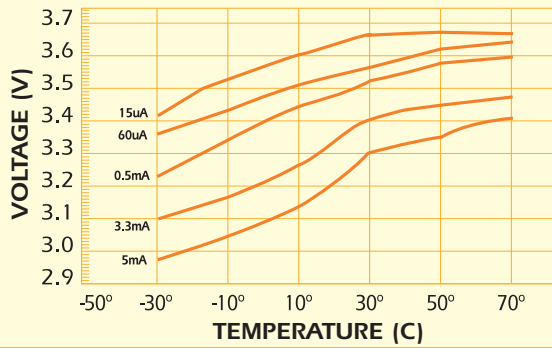

PHYSICAL CHARACTERISTICS

Width (max)	16.8 mm (0.661")
Length (max)	15.8 mm (0.622")
Height (max)	6.8 mm (0.268")
Typical weight	5 g (0.176oz)

CAPACITY VS. CURRENT

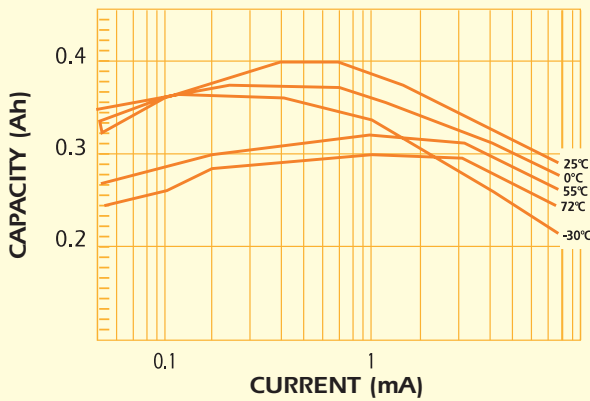

STORAGE CHARACTERISTICS

