



## MODEL EF651615 Lithium Thionyl Chloride (Li-SOCl<sub>2</sub>) Battery

(International size reference: LTC-3PN, EF651615)

### ELECTRICAL CHARACTERISTICS

(Typical values for cells stored for one year or less, at +25°C)

■ **Nominal capacity** **0.40Ah**  
(At 0.5 mA, +25°C, 2.0V cut off. The capacity restored by the cell varies according to current drain, temperature and cut off voltage.)

■ **Nominal voltage** **3.6 V**

■ **Maximum recommended continuous current** **5 mA**  
(To get 50% of the nominal capacity at +25°C with 2.0V cut off. Higher currents possible, consult OmniCel.)

■ **Maximum pulse capability** **20 mA**  
**Rated 1 sec. pulse capability (to 3V)** **10 mA**  
**Pulse capability** varies according to pulse characteristics (frequency and duration), temperature, cell history (storage conditions prior to usage) and the application's acceptable minimum voltage.

■ **Storage** (Recommended) **+30°C max.**  
(For more severe condition consult OmniCel)

■ **Operating temperature range** **-60°C / +85°C**  
(Operation at temperature different from ambient may lead to reduced capacity and lower voltage plateau readings.)

### KEY FEATURES

- ✓ High and stable operating voltage
- ✓ High minimum voltage during pulsing
- ✓ Low self discharge rate (less than 1% after 1 year of storage at +25°C)
- ✓ Stainless steel container
- ✓ Hermetic glass-to-metal sealing
- ✓ Non-flammable electrolyte
- ✓ Non-restricted for transport
- ✓ Compliant with IEC 60086-4 safety standard and EN 60079-11 intrinsic safety standard

UL Underwriters Laboratories (UL)  
Component Recognition  
(File Number MH 28717)

### MAIN APPLICATIONS

- ✓ Utility metering
- ✓ Alarms and security devices
- ✓ Memory back-up
- ✓ Tracking systems
- ✓ Automotive electronics
- ✓ Professional electronics  
... etc.

#### ⚠ WARNING:

Fire, explosion and severe burn hazard. Do not recharge, crush, disassemble, heat above 212°F (100°C), incinerate, or expose contents to water. Do not solder directly to the cell, use tabbed cell instead.

Note: Information in this document is subject to change without notice. Any representations in this data sheet concerning performance are for informational purpose only and are not construed as warranties, either expressed or implied, of future performance.

## Discharge Characteristics @ +25°C

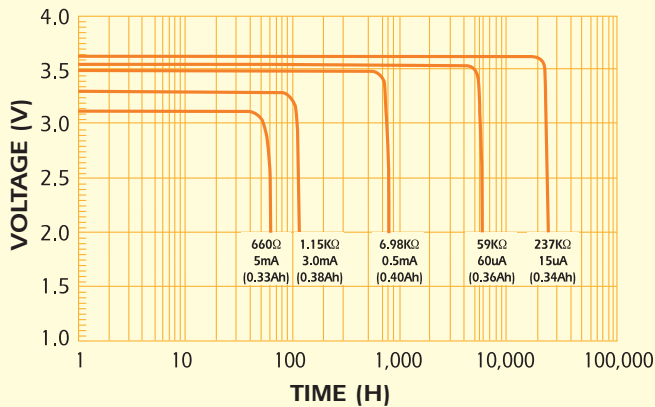

## EF651615

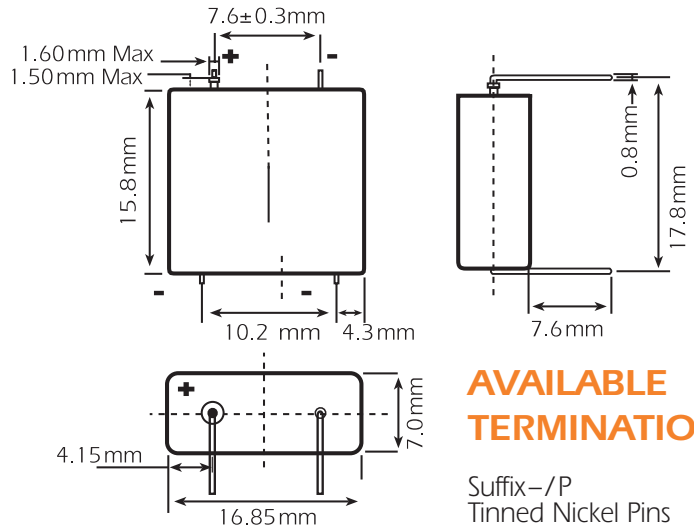

## AVAILABLE TERMINATIONS

Suffix -/P  
Tinned Nickel Pins

## Voltage versus Temperature

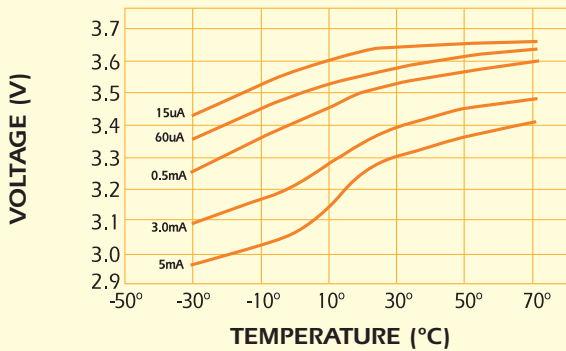

## Physical Characteristics

Width (max)	16.8 mm (0.661")
Length (max)	15.8 mm (0.622")
Height (max)	6.8 mm (0.267")
Typical weight	5 g (0.176oz)
Lithium content	0.10 g (0.003oz)

## Capacity versus Current

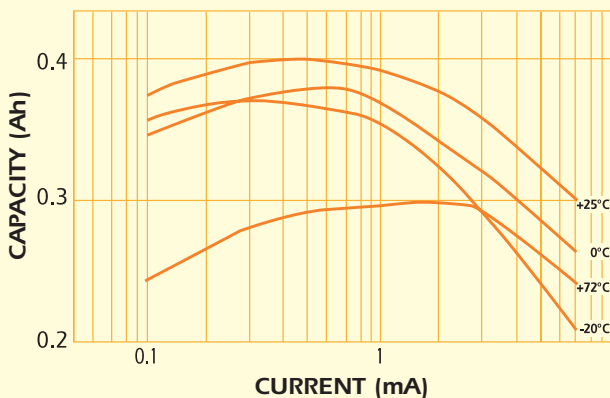

## Storage Characteristics

